

272 Serie 1200

Legenda KIT / Kit Legend

1207	Guida superiore DX-SX <i>Upper runner left-right</i>
1207 E	Guida superiore con o-ring DX-SX <i>Upper runner with o-ring left-right</i>
1209	Guida superiore con o-ring <i>Upper runner with o-ring</i>
1212	Carrello inferiore regolabile con rullo <i>Lower adjustable truck with roller</i>
1213	Carrello inferiore regolabile con cuscinetto <i>Lower adjustable truck with ball bearing</i>
0391	Fermo superiore <i>Upper stopper</i>

Legenda altri componenti / Legend other items

1205		Profilo alluminio superiore <i>Upper aluminium profile</i>	1222		Profilo maniglia alluminio (per spessore 18-22mm) <i>Aluminium handle profile (for thickness 18-22mm)</i>
1215		Profilo alluminio inferiore <i>Lower aluminium profile</i>	1221		Guarnizione plastica (per ART.1222 e ART.1224) <i>Plastic profile (for ART.1222 and ART.1224)</i>
1260		Profilo alluminio inferiore <i>Lower aluminium profile</i>			



Sistemi scorrevoli per armadi / sliding systems for wardrobes

Sezione verticale / Vertical section

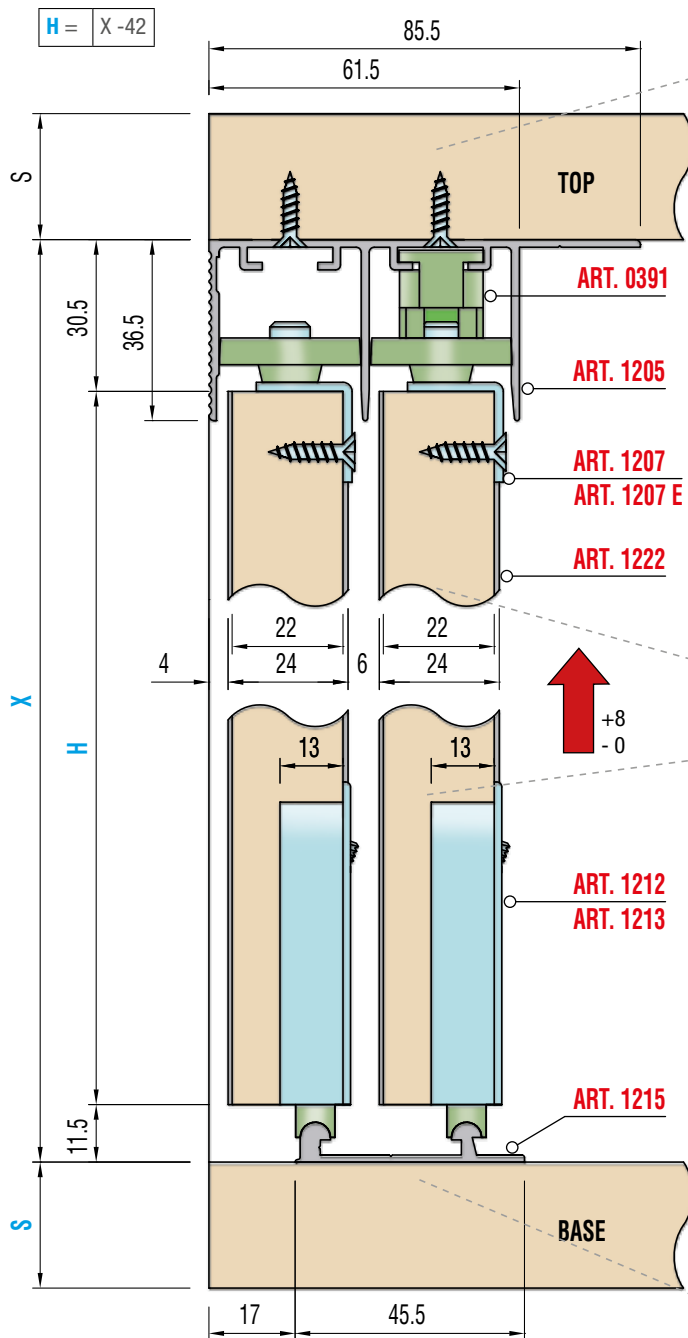

Variante / Special version

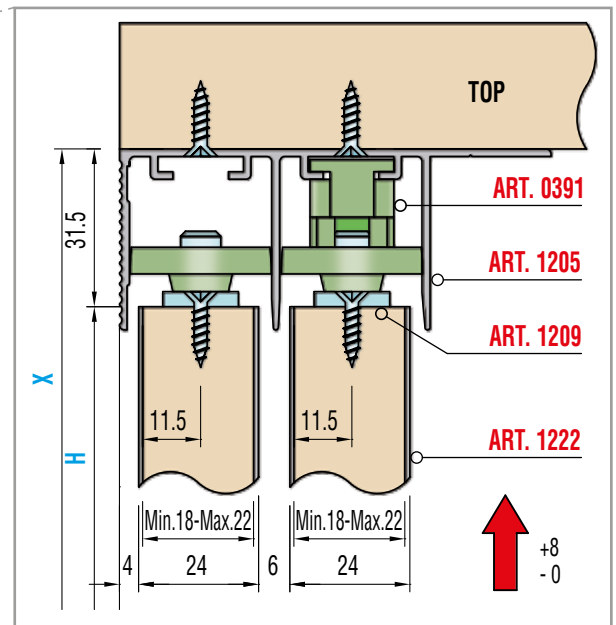

Variante / Special version

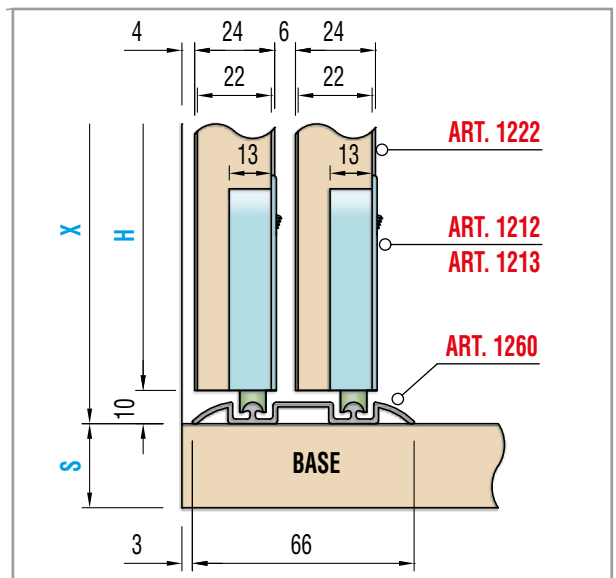

Schema Foratura ante / Doors drilling

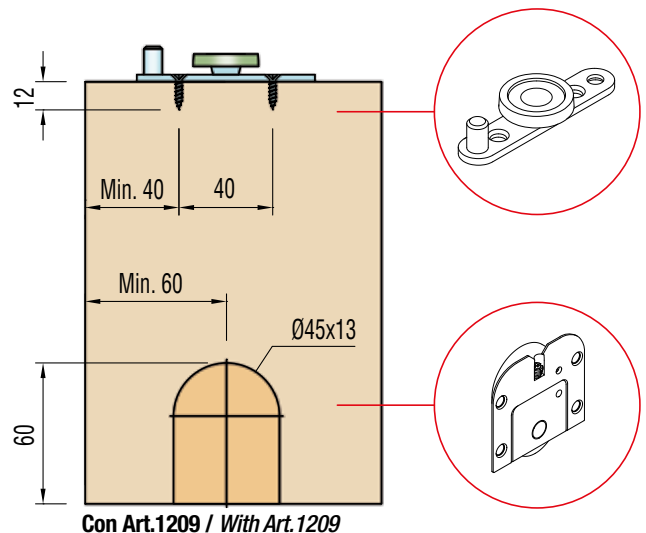
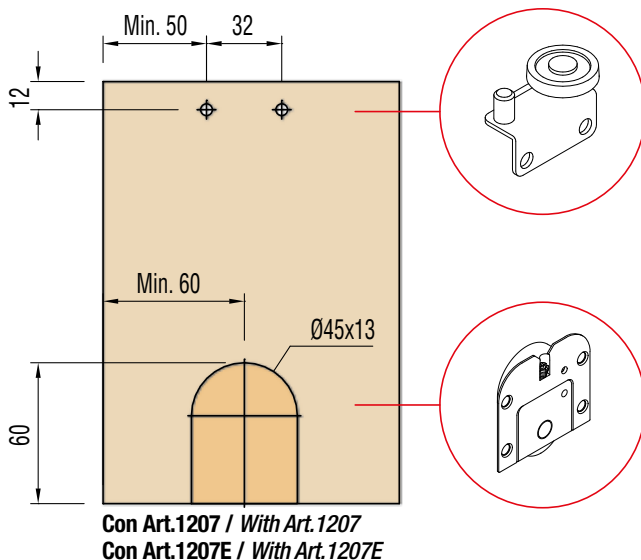



Sistemi scorrevoli per armadi / sliding systems for wardrobes

Schema foratura profili maniglia / Drilling handle profile

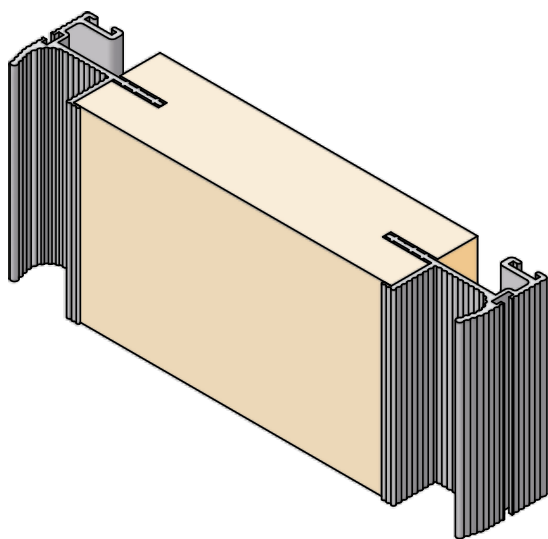

PROFILO MANIGLIA ART.1222 - HANDLE PROFILE ART.1222

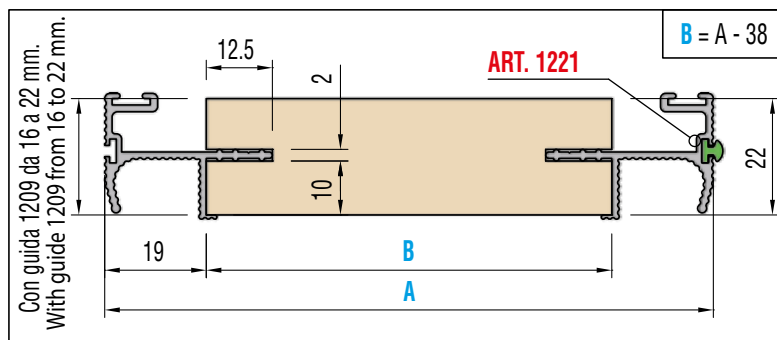

PROFILO MANIGLIA ART.1220 - HANDLE PROFILE ART.1220

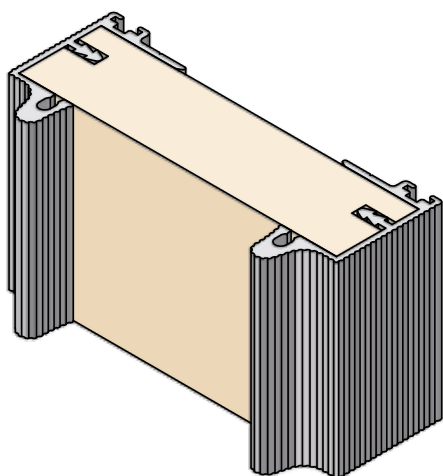
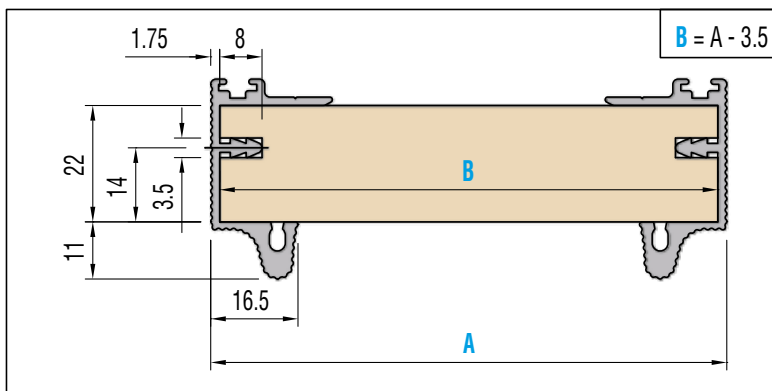

PROFILO MANIGLIA ART.1220 - HANDLE PROFILE ART.1220

